

WELLCOMP TECHNOLOGY CO., LTD

APPROVAL SHEET

Model Name	Chip Current Sensing Resistor -High Power Series
Part Number	WCCSH Series
Customer Name	
Customer P/N	
Issued Date	

Customer		Maker		
Approved	Checked	Inspector	Checked	Prepared

元璽科技股份有限公司



WELLCOMP TECHNOLOGY CO., LTD.

桃園縣龜山鄉南上路 526 號

NO. 526, NangShang RD., Guishan Township

Taoyuan Country 333, Taiwan

Tel: +886-3-2220730, 2220731

Fax: +886-3-2222820

Features

- ◆ Chip size from 0603 to 1206
- ◆ Resistance Value from 20mΩ to 910mΩ
- ◆ Lead free, RoHS compliant for global applications and halogen free

Application

- ◆ Mobile electronic equipment-Cellular phone, NB Tablet PC, GPS, DSC, HDD
- ◆ DC-DC converter, Adapter, Battery pack and charger
- ◆ Switching power supply
- ◆ Voltage Regulation module
- ◆ Power management applications

Part Numbering System

WCCSH **1206** **R050** **F** **I** **x**
 (1) (2) (3) (4) (5) (6)

- (1) Series Code
- (2) Size (EIA): Length x Width
- (3) Resistance: R002=2mΩ, R010=10mΩ
- (4) Tolerance: D=+/-0.5%, F=+/-1%, G=+/-2%, J=+/-5%
- (5) Packaging: T- Embossed paper tape, 7" reel
 E-Embossed plastic tape, 7" reel
- (6) Factory Code

Dimension

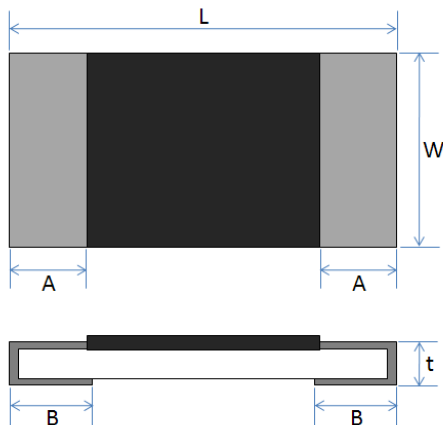

Type	Dimensions				
(inch size)	L	W	t	A	B
0603	1.55±0.10	0.80±0.10	0.45±0.10	0.30±0.20	0.35±0.20
0805	2.10±0.15	1.30±0.15	0.65±0.15	0.40±0.20	0.40±0.20
1206-S Type	3.10±0.20	1.65±0.10	0.65±0.15	0.50±0.30	0.45±0.20
1206-L Type				0.8±0.30	

*Remark: $R \geq 100m\Omega$ is S Type
 $R < 100m\Omega$ is L Type

Electrical Specification

Type	Power Rating	Resistance Range(mΩ)			Operation Temp. Range	TCR (PPM/°C)
		1%	2%	5%		
0603	1/8W	20~99			-55~+155°C	±800
		100~499				±200
0805	1/4W	6~10				±800
		11~100				±400
		101~976				±200
1206	1/2W	6~10				±800
		11~100				±400
		101~976				±200

Note:

(1) Non-Standard resistance values available

Derating Curve

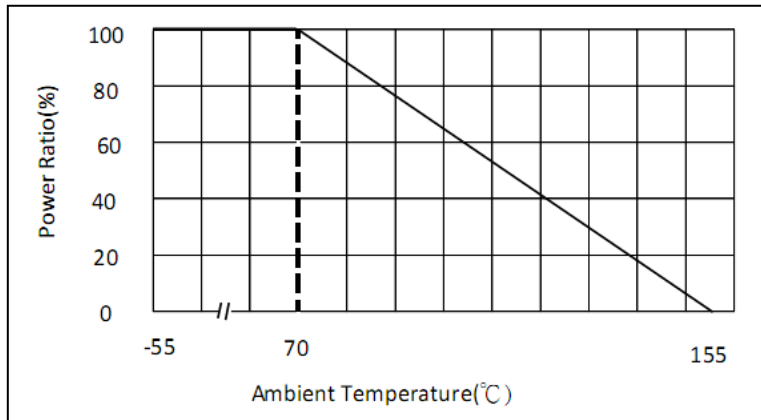

Performances

Environmental Performance

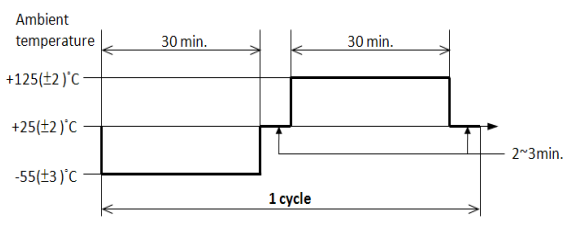
No.	Item	Test Condition	Specification	
			1%, 2%	5%
1	Short Time Overload	5X rated power for 5 sec. (JIS-C5202-5.5)	$\pm(1\%+0.05\Omega)$	$\pm(2\%+0.05\Omega)$
2	Temperature Coefficient of Resistance (T.C.R.)	+25°C /+125°C. (JIS-C5202-5.2) $TCR \text{ (ppm/}^\circ\text{C)} = \frac{\Delta R}{R \times \Delta t} \times 10^6$	Refer to Electrical Specification	
3	Damp Heat with Load	The specimens shall be placed in a chamber and subjected to a relative humidity of 90~95% percent and a temperature of 40° ±2°C for the period of 1000 hrs. (MIL-STD-202, Method 103)	$\pm(2\%+0.05\Omega)$	$\pm(3\%+0.05\Omega)$
4	High Temperature Exposure	The ship (mounted on board) is exposed in the heat chamber 125±3°C for 1000 hrs. (JIS-C5202-7.2)	$\pm(1\%+0.05\Omega)$	$\pm(1.5\%+0.05\Omega)$
5	Load Life	Apply rated power at 70±2°C for 1000 hours with 1.5 hours ON and 0.5 hour OFF. (JIS-C5202-7.10)	$\pm(2\%+0.05\Omega)$	$\pm(3\%+0.05\Omega)$
6	Rapid change of temperature	The chip (mounted on board) is exposed, -55±3°C (30min.)/+125±2°C (30min.) for 5 cycles. The following conditions as the following figure. (JIS-C5202-7.4) 	$\pm(0.5\%+0.05\Omega)$	$\pm(1\%+0.05\Omega)$

Function Performance

No.	Item	Test Condition	Specification	
			1%, 2%	5%
1	Bending Strength	Mount the chip to test substrate. Apply pressure in direction of arrow unit band width reaches 3mm(+0.2/-0mm) illustrated in the figure below and hold for 10±1 sec. (JIS-C5202-6.1) Unit: mm 	±(1%+0.05Ω)	
5	Solvent Resistance	The chip is completed immersion of the specimens in the isopropyl alcohol for 3 *+5, -0) min., 25°C ±5°C. (MIL-STD-202, Method 215)	Verify marking permanency. (Nor required for laser etched parts or parts with no marking)	
6	Resistance to solder Heat	The specimen chip shall be immersed into the flux specified in the solder bath 260±5°C for 10±1 sec. (MIL-STD-202, Method 210)	±(0.5%+0.05Ω)	±(1%+0.05Ω)
7	Solderability	The specimen chip shall be immersed into the flux specified in the solder bath 235±5°C for 2±0.5 sec. It shall be immersed to a point 10mm from its root. (Sn96.5/Ag3.0/Cu0.5) (JIS-C5 202-6.11) 	Solder shall be covered 95% or more of the electrode area.	

Tape Packaging Specifications

◆Paper Tape Specifications

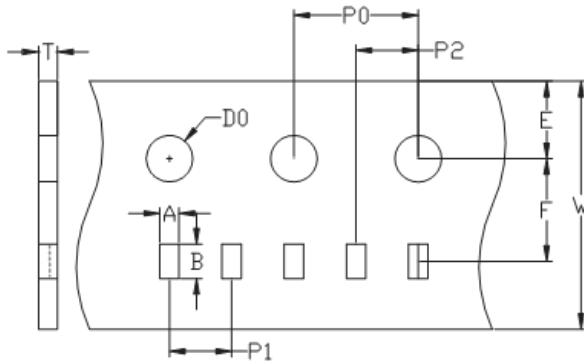

Unit:mm

Type	Carrier Dimensions									
	A	B	E	F	W	P0	P1	P2	D0	T
0603	1.1±0.1	1.9±0.1	1.75±0.1	3.5±0.05	8.0±0.2	4.0±0.1	4.0±0.1	2.0±0.05	1.55±0.05	0.64±0.1
0805	1.6±0.1	2.4±0.1	1.75±0.1	3.5±0.05	8.0±0.2	4.0±0.1	4.0±0.1	2.0±0.05	1.55±0.05	0.97±0.1
1206	2.0±0.1	3.6±0.1	1.75±0.1	3.5±0.05	8.0±0.2	4.0±0.1	4.0±0.1	2.0±0.05	1.55±0.05	0.97±0.1

Packaging

Size EIA (EIAJ)	0603/0805/1206
Standard Packing Quantity (pcs /reel)	5,000

Storage Conditions

Temperature : 5~35°C, Humidity : 40~75%

Recommended Solder Pad Layout

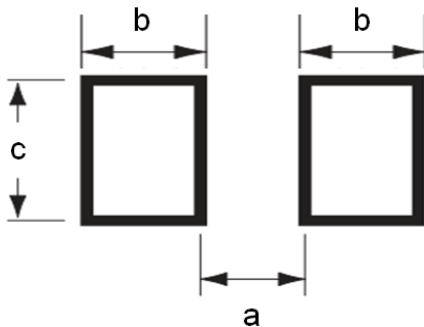

Type	Pad Layout Dimension (mm)		
	a	b	c
0603	0.90	0.70	1.00
0805	1.20	1.20	1.40
1206	2.20	1.30	1.80

Soldering Recommendations

- ◆ Peak reflow temperatures and durations :
 - IR Reflow Peak = 260°C max for 10 sec
 - Wave Solder = 260°C max for 10 sec
- ◆ Compatible with lead and lead-free solder reflow processes
- ◆ Recommended IR Reflow Profile :

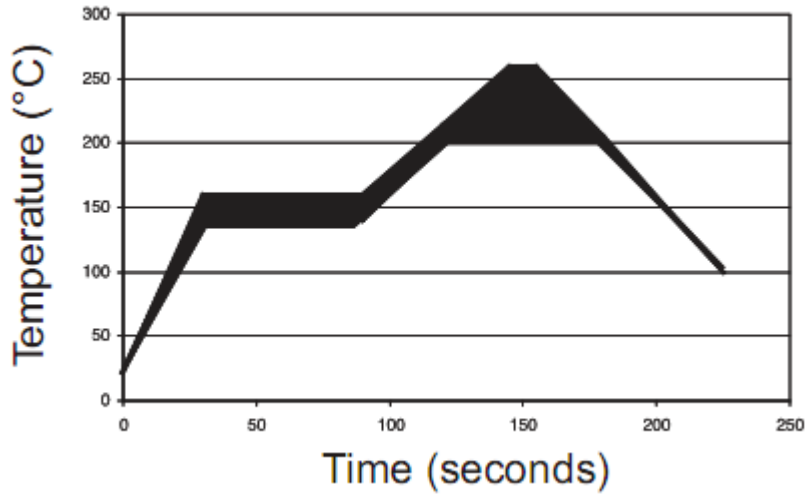

ECN

Engineering Change Notice : The customer will be informed with ECN if there is significant modification on the characteristics and materials described in Approval Sheet.